

Refrigerated Serve Overs - I-Luzon

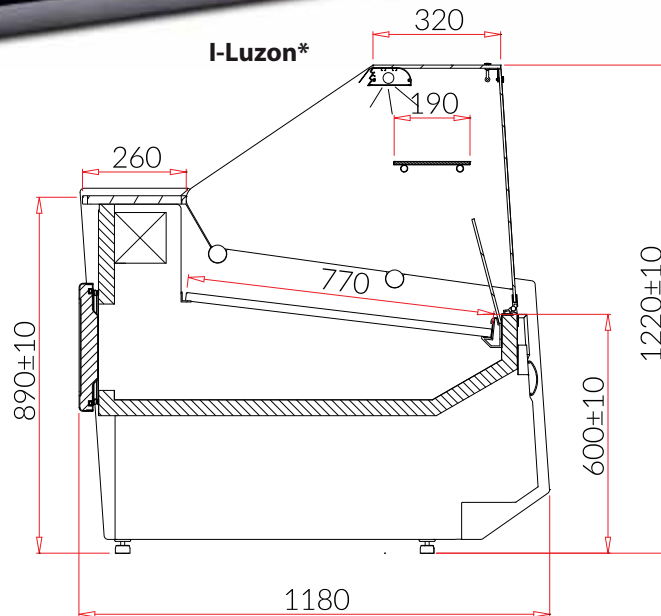
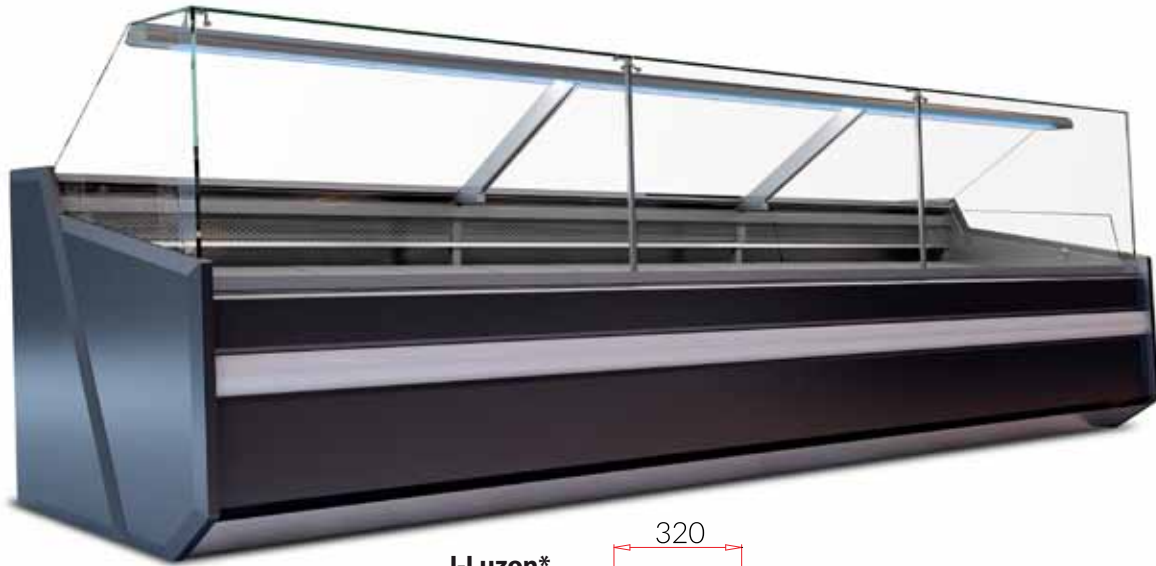

Technical parameters:

| Model | Dimension (ext.) H x W x D [mm] | Display surface [m ²] | Power Consumption [kWh/24h] | Weight [kg] |
|--------------|---------------------------------------|---|-----------------------------------|----------------|
| I-Luzon 0.94 | 1220 x 1020 x 1180 | 0,70 | 4,00 | 155 |
| I-Luzon 1.25 | 1220 x 1330 x 1180 | 1,00 | 4,10 | 175 |
| I-Luzon 1.56 | 1220 x 1645 x 1180 | 1,20 | 5,10 | 205 |
| I-Luzon 1.88 | 1220 x 1960 x 1180 | 1,40 | 6,10 | 230 |
| I-Luzon 2.50 | 1220 x 2580 x 1180 | 1,90 | 8,40 | 305 |
| I-Luzon 3.13 | 1220 x 3210 x 1180 | 2,40 | 9,50 | 435 |
| I-Luzon 3.75 | 1220 x 3830 x 1180 | 2,90 | 13,20 | 510 |

* - Picture above presents unit with either some or all available extras. Please note that the look of basic version of cabinet, or one of your choice, may vary from presented.

Refrigerated Serve Overs - I-Luzon



I-Luzon*

Description:

- temperature range +1 / +8°C
- preferred ambient temperature +16 / +25°C
- power supply 230V / 50Hz
- internal condensing unit
- ecological polyurethane insulation
- external housing made of white coated steel - from staff side
- base and front made of powder coated steel - white
- aluminium glass frames colour - choice of colours
- display deck depth 770mm
- exposition surface made of white coated steel
- refrigerated under-storage made of white coated steel
- 260mm width worktop - made of stainless steel
- electronic control with temperature display
- automatic defrost system
- static air circulation
- square front glass - hinged, openable
- interior LED lighting (meat colour)
- ABS side walls (40mm thick) - choice of colours
- 1 year full warranty service and after warranty service provided

Choice of colours:

Side walls colours: 

Bumper colours: 

Aluminium frames colours: 

Optional colours:

Granites: 

Front colours: 

Base colours: 

Available options:

- multiplexing
- prepared to work with external condensing unit
- external housing made of stainless steel (staff side)
- front panel colour - optional colours
- base colour - optional colours
- front panel made of stainless steel
- base made of stainless steel
- exposition area stepped (2 steps)
- exposition area stepped (3 steps)
- exposition area made of stainless steel
- exposition area made of acid resistant stainless steel
- storage chamber made of stainless steel
- storage chamber made of acid resistant stainless steel
- fans enforcing air circulation
- powder painted evaporator
- worktop made of granite (grey) 20mm thick
- worktop made of granite (blamoral) 20mm thick
- worktop made of granite (black) 20mm thick
- LED light colour (white)
- LED light colour (confectionary)
- additional exposition glass shelf (ambient)
- perspex blinds
- customer front shelf (aluminium profile gold or silver colour)
- set of wheels (castors)
- small movable table (on rails)
- movable partition (glass on stands, placed in exposition area)
- fixed top partition (high glass fixed in exposition area)
- automatic condensate evaporation (internal condensing unit only)
- analog thermometer
- socket with fuse

* - Picture above presents unit with either some or all available extras. Please note that the look of basic version of cabinet, or one of your choice, may vary from presented.